

9.3 BW and TW axes

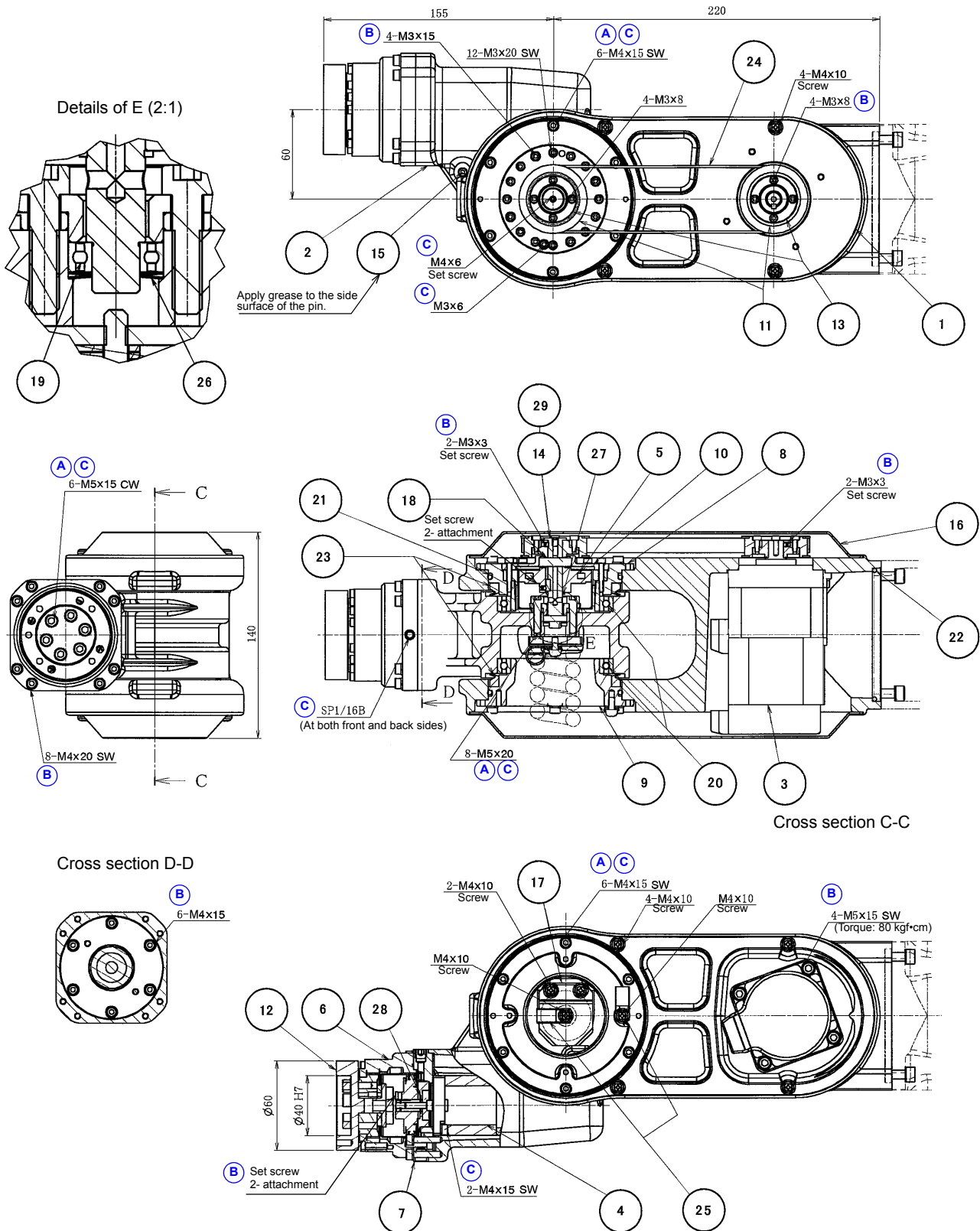

No.	Part name	Part number	Q'ty	Note	Class
1	BW body	ADA21046-01	1		D
2	TW body	ADA21047-01	1		D
3	Servo motor	TS4607N8323	1	BW axis	C
4	Servo motor	TS4603N8030	1	TW axis Previous type: TS4603N8023 ^(*)	C
5	Harmonic	SG2080RR81B	1	BW axis	C
6	Harmonic	SG1750RR81T	1	TW axis	C
7	TW motor plate	AFP32021	1		D
8	HDC housing	ADH32023	1		D
9	Bearing fix	ADH30034-02	1		D
10	HDC cover	AGK31028	1		D
11	Pulley H	ADW41066	2		B
12	TW output flange	ADH40018	1		D
13	Pulley shaft H	ADS41052	1		D
14	BWHDC shaft	ADS41073	1		D
15	CAL pin M4	AAG41005	1		C
16	TWBW cover	ADK32024-01	2		D
17	TW harness holder	AFM41688	1		D
18	Bearing	6900ZZ	1		B
19	Bearing	688ZZ	1		B
20	Bearing	6812LULP03	2		B
21	O-ring	G80	2		A
22	O-ring	G85NBR	1	Front side of joint arm	A
23	V-ring	G75A	2		A
24	Timing belt	100S3M432	1		A
25	Nylon clamp	KCA64	2		A
26	Conical head screw for bear	BDS16	2		B
27	Snap ring	STW10	1		A
28	Snap ring	STW8	1		A
29	Key	AFK40015	2		B

<Class>

A: Consumable parts, rather short replacement cycle.

B: Assemblies and parts of high frequency in motion.

C: Important electric parts.

D: Parts rather long replacement cycle.

(*) For products manufactured before November, 2007.